

GUIDE
TO SAFE
DELIVERY OF
BITUMEN

UK EDITION



GUIDE TO SAFE DELIVERY OF BITUMEN

UK EDITION

June 2011



ISBN 2-930160-20-9

D/2011/7512/21

© Eurobitume 2011

Published by the European Bitumen Association

Boulevard du Souverain 165

B - 1160 Brussels, Belgium

Tel.: +32/(0)2 566 91 40

Fax: +32/0)2 566 91 49

info@eurobitume.eu

www.eurobitume.eu

Refined Bitumen Association

Hammerain House

Hookstone Avenue

Harrogate

HG2 8ER

United Kingdom

Tel.: +44/1423 876 361

www.bitumenuk.com

First edition June 2011

Guide to Safe Delivery of Bitumen

Considerable effort has been made to assure the accuracy and reliability of the information contained in this publication. However, Eurobitume cannot accept liability for any loss, damage or injury whatsoever resulting from the use of this information.

The information in this guide is given in good faith and belief in its accuracy at the time of publication, but does not imply any legal liability or responsibility by the Refined Bitumen Association. The Health and Safety at Work Act 1974 and The Management of Health & Safety Regulations 1999 require employers to provide safe systems of work to ensure the safety of their employees and the public. Health and Safety Law imposes duties on both the supplier and the customer to provide safe systems of work. This guide is intended to help both parties comply with their respective responsibilities during the delivery of bitumen products and is not intended to vary the legal responsibility of either party.

Acknowledgement

Eurobitume is grateful to the members of the Task Force Safe Handling of Bitumen for producing this document

Didier Carré - GPB
Eric Champomier - ExxonMobil
Peter Clement - Petroplus
Philippe Dewez - Eurobitume
Lotfi Elmizhar - Total
Wayne James - Petroplus
Xenia Krüger - Shell, Chair
Paul Lamb - Nynas
Bernard Lombardi - GPB
Ingeborg Schroeder - BP
Mike Southern - Eurobitume
Chris Southwell - RBA
Bodo Wichert - ARBIT



Contents

	Eurobitume guide to safe delivery of bitumen	6
	RBA	7
i	Introduction	8
1	Customer site	9
1.1	Clearly designated routes to and from the delivery points should be provided	9
1.2	A safe and readily accessible delivery point must be provided	9
1.3	At least one emergency shower must be provided	10
1.4	Instructions for the safe delivery operations should be posted in the delivery area	10
1.5	All receipt facilities should be regularly cleaned and checked for serviceability with any defects recorded and rectified	11
1.6	Pipe drainings	11
1.7	A dry powder fire extinguisher must be provided in close proximity to the delivery flange	12
1.8	The customer is responsible for ensuring that all personnel involved in the delivery are aware of the site specific safety and emergency procedures (also refer to 1.1)	12
2	Personal Protective Equipment (drivers and site staff)	13
2.1	Any person present within 6 metres of the delivery point of bitumen, irrespective of their specific duties, must wear appropriate PPE	13
3	Delivery vehicle equipment	14
3.1	The following equipment must be installed	14
3.2	ADR plates and equipment must be available and displayed on the delivery vehicle	14



Contents

4	Operation & maintenance of storage tanks and pipework	15
4.1	Tank markings	15
4.2	Tank gauges	15
4.3	Tank alarms	16
4.4	Tank openings	16
4.5	Tank pipework and flanges	17
4.6	Tank design & use	18
4.7	Storage temperature	18
5	Delivery procedures	19
5.1	Pre-delivery	19
5.2	During delivery	19
5.3	Split loads	21
5.4	Post delivery	21
6	Bitumen specific training	22
6.1	Delivery drivers	22
6.2	Site operatives	22
7	Bitumen safety documentation	23
g	Glossary	24
r	Reference Literature & Legislation	25
a1	Appendix 1 - Personal Protective Equipment	27
a2	Appendix 2 - National requirements	28
a3	Appendix 3 - Tank ullage calculation (from reference 17)	33

Eurobitume guide to safe delivery of bitumen

Eurobitume is an association representing the bitumen producers in Europe. One of its missions is to promote the safe use of bitumen. It encourages good operational, safety and environmental policies and practices for the benefit of all those involved in the delivery of bituminous products.

The Eurobitume guide to safe delivery of bitumen was produced by Eurobitume members to highlight the responsibility of those involved throughout the supply chain and summarise best practices. The document, based mainly on experience in France, Germany and the UK, has been written as a European Guide. For this UK edition adjustments have been included to account for local conditions and regulations.

The laws and regulations in Europe require employers to provide safe systems of work to ensure the safety of their employees and the public. Health and Safety laws impose duties on all relevant stakeholders and on all involved parties to provide safe systems of work. This guide to safe delivery of bitumen is intended to help all parties comply with their responsibilities during the delivery of bitumen products and does not alter the legal responsibility of either party.

The document aims to define the minimum industry standards for design, equipment and procedures based on legislation and experience. These standards should be used by member companies, bitumen hauliers and customer sites. It is specified where standards are mandatory, by stating that such levels must be achieved. In other areas the standards should be seen as industry recommendations, for example where best practice is not currently achievable due to infrastructure or legacy issues.

It is recognised that there are national differences in bitumen delivery practices and legislation, therefore an Appendix has been included in the document (Appendix 2) where additional procedures have been incorporated.

The information and recommendations in this guide are given in good faith and belief in their accuracy at the time of publication, but this does not imply any legal liability or responsibility of the association.

Eurobitume

Website: www.eurobitume.eu





RBA

The Refined Bitumen Association is an association of bitumen producers in the United Kingdom.

Its role is:

1. To promote the use of bitumen in:
 - The construction and maintenance of roads, airfields and other paved areas.
 - Industrial applications, such as roofing, waterproofing and corrosion protection.
2. To provide collective representation for the UK bitumen supply industry with relevant external bodies.
3. To encourage and co-ordinate good operational, safety and environmental policies and practices for the benefit of all those involved in the delivery and handling of bituminous products.

The RBA Code of Practice for the Safe Delivery of Bitumen Products was first published in 1996, reprinted in 1999 and revised in 2001 and 2006. It is replaced by this document.

Refined Bitumen Association
Hammerain House
Hookstone Avenue
Harrogate
HG2 8ER
United Kingdom

Website: www.bitumenuk.com





Introduction

Bitumen is delivered hot (up to 230°C) and frequently under pressure. Therefore exercising extreme caution and correct handling of bitumen help to minimise the risk of burns or other injury to those associated with deliveries as well as damage to the environment or equipment.

This document is intended to raise awareness of safety issues within the delivery process of bitumen and to highlight the responsibilities of those involved within the supply chain according to European legal requirements as well as the ADR regulations. All influencing aspects that may affect any of these participants are considered. Additional considerations such as environmental noise and dust are included in the documentation. It builds on the experience of France, Germany, UK and the USA.

It will require the commitment of all stakeholders:

- Suppliers
- Transporters
- Drivers
- Receivers
- Customers

This document is intended to assist those delivering and receiving bitumen at elevated temperature in bulk tanker loads in reducing the frequency of incidents and accidents by raising awareness of their causes in and by defining good practice.

Good practice is dealt with in the following sections:

- Customer delivery site conditions
- Personal Protective Equipment
- Delivery vehicle equipment
- Operation and maintenance of storage tanks and associated pipework
- Delivery procedures
- Bitumen specific training
- Bitumen safety documentation

A detailed risk assessment of the delivery site and procedures relating to the discharge of bitumen must be carried out and an action plan agreed, with time scales set for rectification of any unacceptable conditions. This should be repeated at regular intervals and not less than once every three years, or after any safety incident, or changes to customer equipment or procedures. It is highly recommended that these safety visits are carried out by professional Safety Advisors. The bitumen supplier will be pleased to assist in this process.

The relevant European safety and environmental regulations are referenced in each section of this document. The relevant UK regulations are stated in Appendix 2.3. This list is not exhaustive. It should be noted that for all sections reference to the Health & Safety at Work Act 1974 is relevant.

1

Customer site

1.1 Clearly designated routes to and from the delivery points should be provided

Legislation/source documentation

References 1, 2, 3

Guidance

- 1.1.1 If drivers are required to weigh their vehicle in and out at the delivery site, a walkway must be provided to enable safe access to and from the vehicle.
- 1.1.2 All approach routes and site access roads should be well lit, particularly during hours of darkness.
- 1.1.3 Clear signage and directions for delivery drivers must be provided on site.
- 1.1.4 Site plans should be available either in hand-out or signage format (see also 1.8, e.g. combine map and site specific safety instructions).

1.2 A safe and readily accessible delivery point must be provided

Legislation/source documentation

References 1, 4, 5, 6, 7

Guidance

- 1.2.1 In deciding the delivery point location, pay due regard to nearby access roads as part of the traffic management system in order to avoid slips, trips and falls.
- 1.2.2 Provide lighting to adequately illuminate the entire discharge area.
- 1.2.3 Keep the need for vehicle reversing to a minimum. Where reversing is required safe procedures should be agreed.
- 1.2.4 Provide a flat even surface without a gradient for the vehicle, where the driver can discharge the load in safety and is protected from other traffic movements.
- 1.2.5 Allow unrestricted movement around the vehicle for the driver (adequate space around the vehicle is required).
- 1.2.6 Access within 6 metres of the delivery point must be restricted only to operatives involved in the delivery operation who are wearing the required Personal Protective Equipment (PPE) (see Appendix 1, also refer to 2.1).

1

Customer site

1.2.7

Provide an area which is tidy and clear of obstruction.

1.2.8

Avoid surrounding or adjacent operations which could impair a safe delivery.

1.2.9

Provide a safe exit route for the driver in the event of an emergency.

1.3

At least one emergency shower must be provided

Legislation/source documentation

References 2, 3, 4, 5, 6, 7, 8

Guidance

Emergency showers must be installed to the following standards (this is occupational safety advice for site design):

1.3.1

It is recommended that the shower should be positioned at a minimum distance of 6 metres and must be no further than 20 metres away from the discharge point. If the shower is positioned within 6 metres of the discharge point it must be screened from the possible effects of bitumen spray.

1.3.2

Clear, safe emergency access, together with clearly visible signs indicating its position.

1.3.3

Capable of immediately providing sustained volumes of clean water for at least 10 minutes from point of activation at any time. Appropriate precautions must be taken to protect the shower from freezing. If the shower becomes inoperative due to freezing, a suitable temporary shower system must be in place prior to the delivery.

1.3.4

Easily operated by an operative in distress, e.g. foot plate.

1.3.5

It is recommended that the shower is alarmed in such a way as to ensure site management are aware of its use.

1.3.6

Undertake and document regular maintenance and periodic testing.

1.3.7

Advice on the treatment of bitumen burns must be displayed in the delivery area and made available in the event of further medical treatment being required (refer to the Eurobitume bitumen burns card).

1.4

Instructions for the safe delivery operations should be posted in the delivery area

Legislation/source documentation

Reference 1

1

Customer site

Guidance

1.4.1

Post clearly identifiable, simple instructions on operational and safety procedures in the immediate area of the customers' inlet pipework.

1.4.2

Clearly explain actions to be taken in the event of incidents (refer to Eurobitume bitumen burns and safe handling cards and section 1.8).

1.5

All receipt facilities should be regularly cleaned and checked for serviceability with any defects recorded and rectified

Legislation/source documentation

Reference 2

Guidance

It is recommended to use suction pumps/ground based pumps for discharging on sites.

1.5.1

Discharge inlet pipework flanges must be free from warping, excessive wear, rust and fractures.

1.5.2

Storage tank gauges and high level alarms must be operational, calibrated and clearly labelled.

1.5.3

Storage tank vent pipes must be free from blockage by bitumen residue.

1.5.4

The pipework between the customer's delivery flange and the storage tank must not be flexible.

1.5.5

Whenever flexible hoses are made available at customer sites, the customer is responsible for their maintenance (including periodic inspection) and function.

1.6

Pipe drainings

Legislation/source documentation

Reference 9

Guidance

1.6.1

It is the customer's responsibility to provide a suitable method (e.g. sand bed) for the collection and disposal of all hose and pipe drainings and that this is used as requested by the driver. The use of the facility should be checked by the customer.

1.6.2

The delivery site should be kept in a clean and tidy condition.

1

Customer site

1.7

A dry powder fire extinguisher must be provided in close proximity to the delivery flange

Legislation/source documentation

References 1, 10

Guidance

1.7.1

At least one 6kg dry powder extinguisher must be provided in close proximity to the delivery. Minimum distance of 6 metres with maximum distance of 20 metres.

1.7.2

Extinguishers should be housed in suitable weather-proof boxes or shrouds to ensure serviceability at all times.

1.7.3

Extinguishers must be inspected regularly and a permanent record maintained.

1.8

The customer is responsible for ensuring that all personnel involved in the delivery are aware of the site specific safety and emergency procedures (also refer to 1.1)

Legislation/source documentation

References 1, 2

Guidance

1.8.1

Site management must document and provide a compilation of site specific safety instructions for bitumen deliveries for both employees and delivery drivers.

1.8.2

Make instructions available to the delivery driver at the point of site entry (i.e. Site Specific Instruction) and provision of this instruction must be documented with signature and date (also refer to section 6).

1.8.3

Site specific safety and emergency procedures should be tested, if possible with appropriately trained staff and local emergency services.

1.8.4

Staff must be trained in site procedures, and emergency procedures must be tested.

2

Personal Protective Equipment (drivers and site staff)

2.1

Any person present within 6 metres of the delivery point of bitumen, irrespective of their specific duties, must wear appropriate PPE

Legislation/source documentation

References 11, 12

Guidance

2.1.1

PPE must be compliant with Appendix 1 or superior standards, be in good condition and fit for purpose.

2.1.2

PPE must be provided by the haulier for all drivers whilst the site must provide PPE for relevant site staff.

2.1.3

All PPE should be regularly checked and cleaned or replaced whenever their function to protect personnel cannot be judged as fit for purpose anymore. Responsibility lies with the user as well as with the company providing the PPE.

3

Delivery vehicle equipment

If further information regarding vehicle equipment under ADR is required, all hauliers and suppliers must have in their employ a Dangerous Goods Safety Advisor (DGSA) as a legal requirement.

Legislation/source documentation

Reference 12

Guidance

3.1 The following equipment must be installed

- 3.1.1 All valve equipment must be accessible from ground level in order to minimise risk of fall from height.
- 3.1.2 Vehicle brake interlocks, or other means to ensure that the vehicle cannot move while driver is on top of the vehicle. Hand rails must be installed on top of the delivery vehicle if the driver is required to climb on top.
- 3.1.3 Emergency Secondary Safety Valve (ESSV) with a minimum of 3 emergency shut down valves at different locations on the delivery vehicle.
- 3.1.4 Reversing camera, sensors, or other similar reversing aid.
- 3.1.5 Reverse noise warning bleeper.

3.2 ADR plates and equipment must be available and displayed on the delivery vehicle

4

Operation & maintenance of storage tanks and pipework

Installation of a suction pump at the customer site is the preferred means of delivery of product from vehicle to storage tank. (It is recognised that there might be infrastructure issues, but suction pumps are preferred rather than pressurised delivery systems).

4.1 Tank markings

Legislation/source documentation

References 3, 13, 16

Guidance

4.1.1

Each tank and its associated delivery pipe and control valve must be independently and uniquely identified with the tank number.

4.1.2

Storage tanks must also display the grade of bitumen held in the tank.

4.1.3

Safe Working Capacity (SWC) must be displayed for each individual storage tank and be visible to the operator (see also 5.1.2).

4.1.4

It is good practice that storage tanks should display a temperature sign in a size suitable for the size of the tank.

4.2 Tank gauges

Legislation/source documentation

References 2, 13

Guidance

4.2.1

Adequate and reliable means of gauging the tank contents and ullage must be available at the discharge point.

4.2.2

Such gauges must clearly identify which tank they refer to and should preferably be visible from the driver's position at the discharge point, or as a minimum in the control room.

4

Operation & maintenance of storage tanks and pipework

4.2.3

Serviceability of content gauges must be regularly checked and maintained, with documentation recorded.

4.2.4

Wherever possible a duplicate gauging system should be provided in the plant control room.

4.3

Tank alarms

Legislation/source documentation

References 2, 13, 17

Guidance

4.3.1

A high level alarm (HLA) and an independent high high level alarm (HHLA) must be installed on each storage tank.

4.3.2

The activation of the HHLA must be independent of the tank contents gauging system and set to trigger at the available capacity of the tank less 7½%.

4.3.3

To avoid product spillage whilst the delivery hose/line is being cleared, the HLA should be set to trigger at the available capacity of the tank less 10% (see Appendix 3).

4.3.4

Alarms must clearly identify which tank they refer to, when activated.

4.3.5

Alarms must be audible and visible to all those responsible, including the delivery driver, for the safe delivery of product.

4.3.6

In the event of an alarm being triggered ground based pumps should automatically switch off and must not re-start until the cause of the alarm has been investigated and resolved (see 5.2.9).

4.3.7

Serviceability of alarms must be regularly checked and maintained, with documentation recorded.

4.3.8

At high temperature the headspace of storage tanks can contain hydrogen sulphide, which may reach dangerous concentrations. Appropriate control measures should be applied which may include delineation of zones, information panels, detectors set to signal if concentrations approach the Occupational Exposure Limit (OEL), use of adequate local ventilation.

4.4

Tank openings

Legislation/source documentation

References 2, 14

4

Operation & maintenance of storage tanks and pipework

Guidance

4.4.1

Vent pipes must be fitted and located where they do not pose a risk to any personnel or delivery vehicles and must be kept clear at all times.

4.4.2

Tank lids must be kept closed and secured at all times during the delivery.

4.4.3

It is recommended that tanks should be fitted with a correctly designed drain valve to enable the safe emptying of the tank for cleaning and maintenance. In the absence of a drain valve, a specific risk assessment must be carried out prior to any uplift of product.

4.4.4

Samples must not be taken from the delivery vehicle or hoses at the delivery site unless equipment is fitted to do so safely.

4.4.5

If there is a requirement to take product samples a purpose designed valve should be permanently fitted to the tank (or corresponding pipework).

4.5

Tank pipework and flanges

Legislation/source documentation

References 2, 14

Guidance

4.5.1

The customer's tank inlet pipework must be of appropriate design, well supported and maintained to ensure no residue will block or seriously reduce the nominal bore of the pipework.

4.5.2

Flanges should be located between 500mm (as measured from the bottom of the flange face) and 1000mm above ground level (as measured to the top of the flange face).

4.5.3

Connection flange design should be standard, well designed and maintained (see Appendix 2.2 for flange design). It is recommended not to use adaptors.

4.5.4

Access to the customer's delivery flange must be such as to allow for safe and easy connection of the delivery hose.

4.5.5

The distance between the delivery vehicle and the storage tank flanges must not be more than one hose length in order to avoid two flexible hoses being connected to each other.

4.5.6

A connection security system (e.g. locks) should be fitted to control discharge, prevent cross contamination and possible spillage. Each system should be robust, tank specific and fit for purpose.

4.5.7

All storage tank pipework should be insulated.

4

Operation & maintenance of storage tanks and pipework

4.6

Tank design & use

Legislation/source documentation

References 2, 15

Guidance

4.6.1

If customer tanks are fitted with inlet/fill pipes that pass through the top of the tank and extend to the bottom of the tank (to minimise oxidation of the bitumen during circulation), the inlet pipe must be slotted or fitted with an alternative device to prevent spillages resulting from siphoning at the end of the delivery.

4.6.2

All access ladders and walkways on tank roofs must be fitted with suitable guards to prevent falls.

4.6.3

Where other product storage tanks, e.g. bitumen emulsion, kerosene, etc. are present, all supply and return pipework must be segregated from the bitumen pipework system and identified.

4.6.4

Where out of service bitumen tanks are being returned to service after maintenance or long interruption, clear procedures must be developed to ensure that the tank is safe to operate and is free of water.

4.7

Storage temperature

Legislation/source documentation

References 13, 18

Guidance

4.7.1

For recommended operating and maximum storage temperatures please refer to the supplier's recommendations.

5

Delivery procedures

5.1 Pre-delivery

Legislation/source documentation

References 2, 17

Guidance

- 5.1.1 It is the responsibility of the customer to authorise each delivery (see also 5.4.3 and Appendix 2 for Bitumen Discharge Permit).
- 5.1.2 It is the customer's responsibility to ensure that there is sufficient tank ullage. Sufficient ullage to take the load plus +10% safety margin must be provided (refer to Appendix 3 for calculation of ullage).
- 5.1.3 It is the responsibility of the customer to confirm that the grade and quantity being delivered are correct, as stated on the drivers' delivery documentation, preferably in writing.
- 5.1.4 It is the responsibility of the customer to confirm that the driver has connected to the appropriate tank receiving flange for the delivery and the lines and valves are routed to correct tanks.
- 5.1.5 The customer must make sure the emergency safety shower is working.
- 5.1.6 Where necessary guard rail systems provided on the delivery vehicle, or by the customer must be used for work at height. It is the responsibility of the customer to ensure that the equipment is used (see section 3).
- 5.1.7 The vehicle must be immobilised by engaging the braking system and, if necessary, wheel chocks should be used.

5.2 During delivery

Legislation/source documentation

References 2, 13

Guidance

- 5.2.1 The customer is responsible for the driver's well-being whilst on their premises.

5

Delivery
procedures

5.2.2

The customer must monitor the driver's safety during the discharge process by at least one of the following methods:

- A) Visually monitoring, e.g. line of sight or CCTV; or
- B) Regular checks made during the delivery process as per site specific risk assessment for bitumen delivery; or
- C) Attend the discharge process with the driver.

5.2.3

When the customer's representative is in the vicinity of the discharge point they must wear appropriate protective clothing as stated in Appendix 1 (see also 1.2.6 and 2.1.2).

5.2.4

No personnel are permitted on top of the storage tanks or on top of the delivery vehicle during the delivery.

5.2.5

Only personnel directly involved in the delivery process and wearing correct PPE are permitted in the 6 metre area surrounding the delivery hose.

5.2.6

Where tanks are situated inside buildings, activities inside the building must be kept to a minimum and notice must be given that a delivery is taking place (e.g. mobile sign). Entry to the building must be restricted to authorised personnel only.

5.2.7

The driver is solely responsible for the operation of his vehicle and equipment throughout the discharge procedure and must remain by the vehicle shut off valves whilst discharge is taking place.

5.2.8

The driver must wear the required PPE at all times during the discharge process as stated in Appendix 1.

5.2.9

In case of an alarm, discharge of product should stop and must not resume until the cause of the alarm has been identified and resolved (see 4.3.6 and Appendix 2.1 for Authority to Continue Discharge).

5.2.10

Appropriate control measures should be applied at delivery sites to reduce the residual quantity of hydrogen sulphide potentially present, this may include delineation of zones, information panels, detectors set to signal if concentrations approach the Occupational Exposure Limit (OEL), driver training, documentation, use of adequate local ventilation.

5.2.11

The driver is authorised to stop the discharge whenever he is concerned about the safety of the delivery for any reason (e.g. people without PPE entering the 6 metre zone, vehicle movements in close vicinity, etc.).

5.2.12

At the end of the delivery the driver should minimise the amount of air that is blown into the tank to avoid the formation of a flammable atmosphere in the storage tank headspace.

5

Delivery
procedures

5.3 Split loads

Guidance

- 5.3.1 Split loads are not recommended and should be avoided whenever possible.
- 5.3.2 If the load is to be delivered into more than one tank, each tank must be treated as a separate delivery point.
- 5.3.3 If the vehicle needs to be moved, the delivery procedure must be repeated in full. This will require the removal of the delivery hose from both vehicle outlet and customer flange.
- 5.3.4 Delivery documents must be endorsed by the customer accordingly to identify the additional tank(s) and, in particular, that ullage and grade checks have been completed prior to delivery.

5.4 Post delivery

Legislation/source documentation

Reference 13

Guidance

- 5.4.1 The driver must clear all discharge delivery pipework and disconnect the vehicle delivery hose.
- 5.4.2 All hose drainings must be disposed of in a safe and suitable receptacle provided by the customer for this purpose, e.g. a sand bed.
- 5.4.3 On completion of the delivery, it is the customer's responsibility to complete and sign the delivery documents to acknowledge receipt of the load. The customer will also confirm that the pipework connection security system is reinstated and the delivery area is clean and tidy.
- 5.4.4 Drivers are encouraged to report any defects that they identify at customer sites, preferably to the customer and to the bitumen supplier, so that joint corrective action can be taken.
- 5.4.5 Any non-compliance to site specific rules or the driver's delivery procedures, the customer must promptly report to the bitumen supplier and/or haulier who will investigate and take corrective action. The customer must intervene immediately and appropriately.
- 5.4.6 After unloading bitumen, personnel should allow gases and vapours to dissipate before closing the manhole. Avoid breathing the vapours, which escape when the manhole is opened or closed.

6

Bitumen specific training

6.1

Delivery drivers

Legislation/source documentation

References 2, 12, 13

Guidance

6.1.1

Hauliers are responsible for ensuring that their drivers have received training and instruction on loading, transport and unloading the vehicle.

6.1.2

All drivers employed in the transportation and delivery of bitumen products must have received training and been issued with an ADR Vocational Training Certificate (VTC) for the relevant class, in tanks. Drivers must have their ADR VTC with them at all times.

6.1.3

All drivers must additionally receive industry specific hazard awareness and safety training prior to working unassisted (see 6.2.2 and Appendix 2.1 for bitumen driver's passport). Drivers can protect their own safety by understanding the potential risks related to the operations of transport of the bitumen and by following good working practices.

6.1.4

Site specific induction of drivers must be provided by the customer on operations and safety and emergency response and provision must be documented by customer personnel (see section 1.8.1).

6.2

Site operatives

Legislation/source documentation

Reference 2

Guidance

6.2.1

Customer representatives and operatives must receive competence training on the safe handling, storage and receipt of bitumen products. Workers can protect their own safety by understanding the potential risks related to the operations of transport of the bitumen and by following good working practices.

6.2.2

Most bitumen suppliers will, upon request, offer assistance and advise on bitumen training.

6.2.3

Training requirements should be reviewed regularly and refresher training provided every three years.

6.2.4

Training records of all individuals must be kept on file.

7

Bitumen safety documentation

Eurobitume Bitumen Burns Card

(see <http://www.eurobitume.eu/hse/safe-handling/burns-cards>)

Eurobitume Safe Handling of Bitumen Card

(see <http://www.eurobitume.eu/hse/safe-handling/safe-handling-cards>)

Eurobitume ADR Guidance Document

(see <http://www.eurobitume.eu/hse/safe-handling/adr>)



Glossary

- ADR: European Agreement concerning the International Carriage of Dangerous Goods by Road
- CCTV: Closed Circuit Television
- DGSA: Dangerous Goods Safety Advisor
- ESSV: Emergency Secondary Safety Valve
- OEL: Occupational Exposure Limit
- PPE: Personal Protective Equipment
- SWC: Safe Working Capacity
- VTC: Vocational Training Certificate

r

Reference Literature & Legislation

- 1 Council Directive 89/654/EEC of 30 November 1989 concerning the minimum safety and health requirements for the workplace
- 2 Council Directive 89/391/EEC of 12 June 1989 on the introduction of measures to encourage improvements in the safety and health of workers at work
- 3 Council Directive 92/58/EEC of 24 June 1992 on the minimum requirements for the provision of safety and/or health signs at work
- 4 Council Directive 89/677/EEC of 21 December 1989 amending for the eighth time Directive 76/769/EEC on the approximation of the laws, regulations and administrative provisions of the member states relating to restrictions on the marketing and use of certain dangerous substances and preparations
- 5 Council Directive 1999/38/EC of 29 April 1999 amending for the second time Directive 90/394/EEC on the protection of workers from the risks related to exposure to carcinogens at work and extending it to mutagens
- 6 Council Directive 98/24/EC of 7 April 1998 on the protection of the health and safety of workers from the risks related to chemical agents at work (fourteenth individual Directive within the meaning of Article 16(1) of Directive 89/391/EEC)
- 7 Directive 2000/54/EC of the European Parliament and of the Council of 18 September 2000 on the protection of workers from risks related to exposure to biological agents at work (seventh individual directive within the meaning of Article 16(1) of Directive 89/391/EEC)
- 8 The European Guidelines for Control and Prevention of Travel Associated Legionnaires' Disease; http://www.ewgli.org/data/european_guidelines.htm
- 9 Council Directive 91/689/EEC of 12 December 1991 on hazardous waste
- 10 Fire safety legislation
- 11 Council Directive 89/656/EEC of 30 November 1989 on the minimum health and safety requirements for the use by workers of personal protective equipment at the workplace (third individual directive within the meaning of Article 16 (1) of Directive 89/391/EEC)

R

Reference Literature & Legislation

12

ADR 2009 - <http://www.unece.org/trans/danger/publi/adr/adr2009/09ContentsE.html>

13

Energy Institute Model Code of Safe Practice/Bitumen Safety Code Part 11. (4th Edition)

14

Council directive 94/9/EC, Equipment and protective systems intended for use in potentially explosive atmospheres

15

Directive 2001/45/EC of the European Parliament and of the Council (OJ No L 195, 19.7.02, p.46) amending Council Directive 89/655/EEC concerning the minimum safety and health requirements for the use of work equipment by workers at work (second individual Directive within the meaning of Article 16(1) of Directive 89/391/EEC

16

EN 13108: Part 21 - Bituminous mixtures - Material specifications - Part 21: Factory Production Control.

17

RBA/MPA Guidance for Safe Bitumen Tank Management

18

Updated Eurobitume Technical Guidance on Maximum Safe Handling Temperatures for Bitumen, Eurobitume, 2007

a1

Appendix 1 – Personal Protective Equipment

Minimum level of PPE for all personnel around the delivery. Higher level of PPE may be required locally.

- Head protection:
 - Helmet (preferably fitted with chin strap)
 - Neck apron
 - Full visor to protect the face
 - Site specific additional equipment: safety spectacles/goggles, ear defenders
 - i) Safety helmet approved to BS EN 397
 - ii) Neck apron approved to BS EN 470-1 & BS EN 531 A B1 C1
 - iii) Full face visor approved to BS EN 166-1F
 - iv) Eye protection approved to BS EN 166-1F
 - v) Ear defenders approved to BS EN 352-2
- Gauntlet gloves with long sleeves.
 - Gloves approved to BS EN 420 and BS EN 388 and must be 14 inches (355 mm) long
- Safety boots: Rigger style boot*.
 - Boots approved to BS EN 345 S3 HRO
- Coverall: 100% Cotton Fire Retardant Coverall complying with EN ISO 11612 Protective clothing for workers exposed to heat (preferably Proban® or similar treated). Note: Some sites may also require anti-static treatment. EN 1149 Protective clothing: Electrostatic properties.
 - Coverall approved to BS EN 471 Class 3 and EN 531 A B1 C1.
 - Coverall legs to be worn over boots



* Rigger style boot, with the coverall legs overlapping the boots, are deemed to provide the best protection of the lower legs and feet from hot bitumen burns.



Appendix 2 - National requirements

Appendix 2.1 Delivery procedures

Risk assessment

A detailed risk assessment of the delivery site and procedures relating to the discharge of bitumen (The Management of Health and Safety at Work Regulations 1999) must be carried out and an action plan agreed, with time scales set for rectification of any unacceptable conditions. This should be repeated at regular intervals and not less than once every three years, or after any safety incident, or changes to customer equipment or procedures. It is recommended that these safety visits or audits are carried out by professional Safety Advisors. The bitumen supplier will be pleased to assist in this process.

Bitumen Discharge Permit (BDP)

It is recommended that a BDP is completed before any bitumen discharge. The BDP should be completed by the customer and signed by both the customer and the delivery driver (see 5.1.1 and 5.1.2).

Authority To (Continue) Discharge (ATD)

If the load is to be delivered into more than one tank, each tank must be treated as a separate delivery point, and an ATD must be completed. It is recommended that a new BDP is completed (see 5.3.2 and 5.3.4).

RBA bitumen driver's passport

All drivers must receive industry specific hazard awareness and safety training prior to being issued with their RBA bitumen driver's passport and working unassisted, and refresher training provided at least every three years (see 6.1.3).

a2

Appendix 2 - National requirements

Appendix 2.2 Delivery flange design

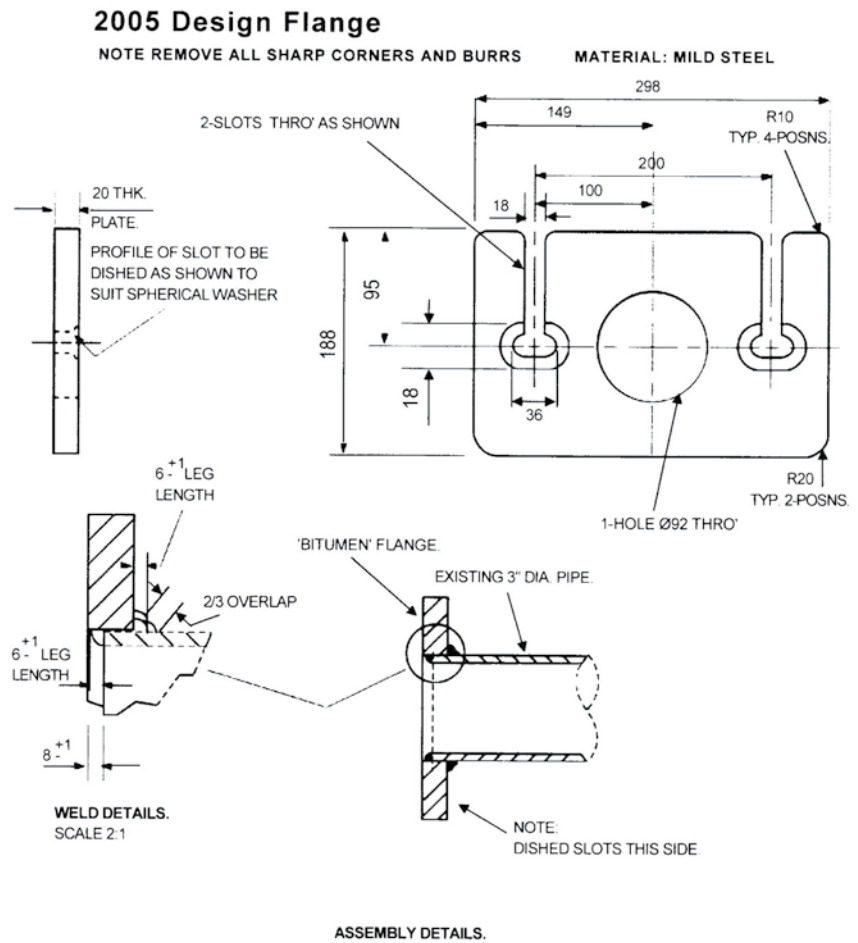

Appendix 2.3 UK national reference literature and legislation

For each section of this guide, a list of the relevant safety and environmental regulations are stated. This list is not exhaustive. It should be noted that for all sections reference to the Health & Safety at Work Act 1974 is relevant.

Section 1.1 The Workplace (Health, Safety and Welfare) Regulations 1992

Health and Safety at Work Act 1974

Health and Safety (Safety Signs and Signals) Regulations 1996

The Management of Health and Safety at Work Regulations 1999

Section 1.2 The Workplace (Health, Safety and Welfare) Regulations 1992

The Management of Health and Safety at Work Regulations 1999

Control of Substances Hazardous to Health (COSHH) Regulations 2002



Appendix 2 - National requirements

- Section 1.3** Health and Safety (Safety Signs and Signals) Regulations 1996
The Management of Health and Safety at Work Regulations 1999
Control of Substances Hazardous to Health (COSHH) Regulations 2002
Construction (Design and Management) Regulations 2007
The Control of Legionella Bacteria in Water Systems - Accepted Code of Practice, L8 (Third Edition 2000)
The Provision and Use of Work Equipment Regulations 1998
Bitumen Deliveries Emergency Safety Shower Guidance, RBA
- Section 1.4** The Workplace (Health, Safety and Welfare) Regulations 1992
Health and Safety at Work Act 1974
The Management of Health and Safety at Work Regulations 1999
- Section 1.5** The Quarry Regulations 1999
The Provision and Use of Work Equipment Regulations 1998
Position Paper on the Use of Ground Based Pumps at Customer Sites, RBA
- Section 1.6** The Quarry Regulations 1999
Waste Management Regulations 1994
- Section 1.7** The Workplace (Health, Safety and Welfare) Regulations 1992
The Management of Health and Safety at Work Regulations 1999
Regulatory Reform (Fire Safety) Order 2005
- Section 1.8** The Workplace (Health, Safety and Welfare) Regulations 1992
Health and Safety at Work Act 1974
Health and Safety (Safety Signs and Signals) Regulations 1996
The Management of Health and Safety at Work Regulations 1999
The Health and Safety Information for Employees (amendment) Regulations 2009



Appendix 2 - National requirements

Section 2.1 Health and Safety at Work Act 1974

The Management of Health and Safety at Work Regulations 1999

Personal Protective Equipment at Work Regulations 1992

ADR 2009 <http://www.unece.org/trans/danger/publi/adr/adr2009/09ContentsE.html>

Safety Footwear Risk Assessment for Bitumen Delivery Drivers, RBA

Section 3.1 ADR 2009 <http://www.unece.org/trans/danger/publi/adr/adr2009/09ContentsE.html>

The Provision and Use of Work Equipment Regulations 1998

Section 4.1 Health and Safety (Safety Signs and Signals) Regulations 1996

Energy Institute Model Code of Safe Practice / Bitumen Safety Code Part 11 (4th Edition)

EN 13108: Part 21 - Bituminous mixtures - Material specifications - Part 21: FPC

New Hot Bitumen Storage Tank Construction Guidelines, RBA

Section 4.2 Energy Institute Model Code of Safe Practice / Bitumen Safety Code Part 11 (4th Edition)

The Provision and Use of Work Equipment Regulations 1998

Guidance for Safe Bitumen Tank Management, RBA/MPA

Study of Asphalt Industry Bitumen Storage Tank Measuring Systems, RBA

Section 4.3 Energy Institute Model Code of Safe Practice / Bitumen Safety Code Part 11 (4th Edition)

The Provision and Use of Work Equipment Regulations 1998

Guidance for Safe Bitumen Tank Management, RBA/MPA

s4.4

Section 4.4 Control of Substances Hazardous to Health (COSHH) Regulations 2002

Dangerous Substances and Explosive Atmospheres (DSEAR) Regulations 2002

The Provision and Use of Work Equipment Regulations 1998





Appendix 2 - National requirements

- Section 4.5** Dangerous Substances and Explosive Atmospheres (DSEAR) Regulations 2002
The Provision and Use of Work Equipment Regulations 1998
- Section 4.6** Construction (Design and Management) Regulations 2007
Dangerous Substances and Explosive Atmospheres (DSEAR) Regulations 2002
The Provision and Use of Work Equipment Regulations 1998
The Working at Height Regulations 2007
Energy Institute Model Code of Safe Practice / Area Classification Code for Installations Handling Flammable Fluids Part 15 (3rd Edition)
Guidance for Returning Bitumen Storage Tanks to Service, RBA
- Section 5.1** Health and Safety at Work Act 1974
The Management of Health and Safety at Work Regulations 1999
Guidance for Safe Bitumen Tank Management, RBA/MPA
- Section 5.2** The Management of Health and Safety at Work Regulations 1999
Energy Institute Model Code of Safe Practice / Bitumen Safety Code Part 11 (4th Edition)
Dangerous Substances and Explosive Atmospheres (DSEAR) Regulations 2002
The Provision and Use of Work Equipment Regulations 1998
- Section 5.3** The Management of Health and Safety at Work Regulations 1999
- Section 5.4** The Management of Health and Safety at Work Regulations 1999
Waste Management Regulations 1994
Energy Institute Model Code of Safe Practice / Bitumen Safety Code Part 11 (4th Edition)
- Section 6.1** The Management of Health and Safety at Work Regulations 1999
ADR 2009 <http://www.unece.org/trans/danger/publi/adr/adr2009/09ContentsE.html>
Energy Institute Model Code of Safe Practice / Bitumen Safety Code Part 11 (4th Edition)
- Section 6.2** Health and Safety at Work Act 1974



Appendix 3 - Tank ullage calculation (from reference 17)

Nominal Tank Capacity	Internal volume in m ³ from the tank bottom to the tank top
Unavailable Tank Capacity	Internal volume in m ³ from the normal tank draw off pipework to the bottom of the tank + Inside volume in m ³ from the overfill/vent pipe to the tank top
Available Tank Capacity	Internal volume in m ³ from the normal tank draw off pipework to the overfill/vent pipe
Safe Working Tank Capacity	90% of the available tank capacity in m ³
Conversion from volume to mass	Multiply volumes in m ³ by 0.92 tonnes/m ³ to express the capacity in tonnes

By way of an example in the use of these terms and to show how confusion can arise, consider a new tank recently installed on a site to hold 100 tonnes of bitumen.

Nominal Tank Capacity	105.8 m ³	97.3 tonnes
Unavailable Tank Capacity	5.3 m ³ + 1.0 m ³ = 6.3 m ³	5.8 tonnes
Available Tank Capacity	99.5 m ³	91.5 tonnes
Safe Working Tank Capacity	89.6 m ³	82.4 tonnes

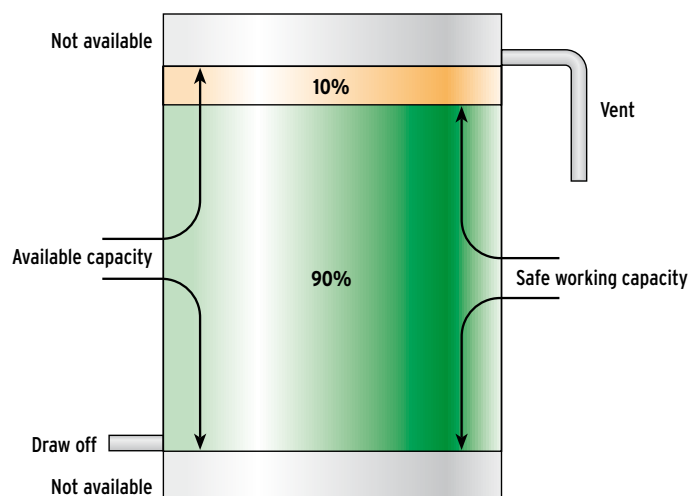

Safe working capacity is 90% of available capacity



 eurobitume



European Bitumen Association

Boulevard du Souverain 165, B - 1160 Brussels, Belgium

Tel.: +32/(0)2 566 91 40 www.eurobitume.eu

Refined Bitumen Association

Hammerain House, Hookstone Avenue, Harrogate, HG2 8ER, United Kingdom

Tel.: +44/1423 876 361 www.bitumenuk.com